

MICROSCAN®

NERLITE® DF-50 Dark-Field Illuminators

The **DF-50 Series** of dark-field illuminators provides low-angle illumination to the region of interest. The unit uses a single tier of LEDs mounted 70° to the optical axis. The light enhances the contrast of surface features such as laser, embossed or engraved marks or surface defects. The light is particularly suited for applications such as BGA ball placement, laser-etched symbologies and surfaces with geometric contours.



Model #	Description
NER-010609310	DF-50, R LED-ND, 12V-C
NER-010609311	DF-50, R LED-ND, 24V-C
NER-010609312	DF-50, R LED-ND, 24V-S
NER-010609320	DF-50, W LED-ND, 12V-C
NER-010609321	DF-50, W LED-ND, 24V-C
NER-010609322	DF-50, W LED-ND, 24V-S
NER-010609330	DF-50, B LED-ND, 12V-C
NER-010609331	DF-50, B LED-ND, 24V-C
NER-010609332	DF-50, B LED-ND, 24V-S

Description Key Example

Dx-xxx-x, R LED-D, 12V-C

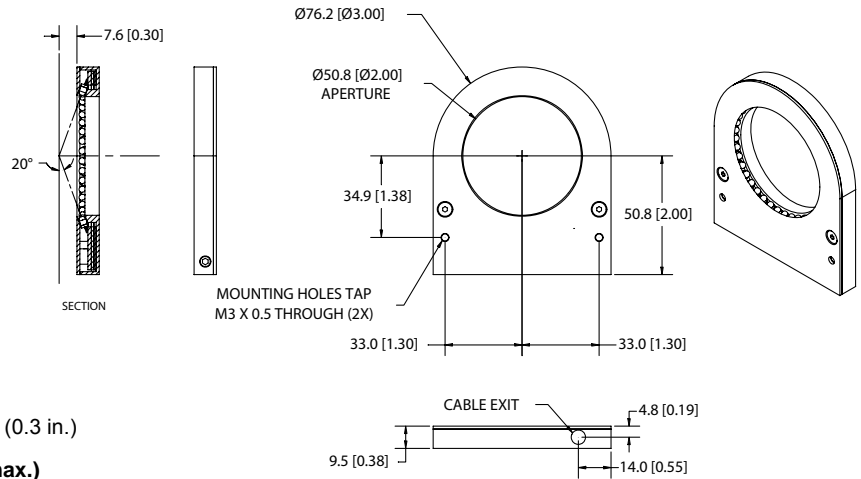
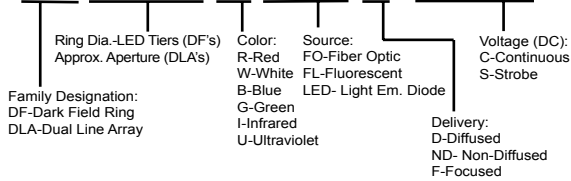

Illumination & Electrical:

Lighting Technique: Dark-field
Light Aperture: 50.8 mm (2.0 in.)
Field Of View x Stand-Off ¹: 17.8 mm (0.7 in.) x 7.6 mm (0.3 in.)
Light Characteristics:

Source	Color (nm)	Exp. Life	Voltage/Current (max.)		
			12V-C	24V-C	24V-S ²
LED	Red plus (660)	50k hrs.	126 mA	69 mA	1.2 A pk. ²
LED	White – 6500 Kelvin	10k hrs.	240 mA	120 mA	2.4 A pk. ²
LED	Blue (470)	10k hrs.	240 mA	120 mA	2.4 A pk. ²

¹ Suggested

² Maximum strobe pulse width = 1.3ms

CE Conformity: Yes

Mechanical:

L x W x H (mm/in.): 88.9 mm x 76.2 mm x 9.5 mm
 (3.5 in. x 3.0 in. x 0.38 in.)
Mounting: (2) M3 x 0.5 through holes
Housing Material: Black Anodized Aluminum
Weight: 136 grams (4.8 oz.)

Environmental:

Max. Operating Humidity: 95% non-condensing
Operating Temp. 40°C (104°F)
Storage Temp. 50°C (122°F)

Accessories:

Part #	Description	Models Used On
NER-010500301	CPS-12 3.5A, 12VDC, US Cord	12V-C
NER-010500303	CPS-12 3.5A, 12VDC, EU Cord	12V-C
NER-010501402	CPS-24, 24VDC, US cord	24V-S ¹
NER-010501401	CPS-24, 24VDC, EU cord	24V-S ¹
NER-010502601	CPS-24T, 24VDC US w/9-pin D-sub	24V-C & 24V-S ¹
NER-010502602	CPS-24T, 24VDC EU w/9-pin D-sub	24V-C & 24V-S ¹
NER-010502700	ICM-1, M/D Intensity Cntrl, 12V-C	12V-C
NER-010502701	ICM-1, M/D Intensity Cntrl, 24V-C	24V-C ²
NER-010502702	SCM-1, 1 Channel M/D Strobe Cntrl.	24V-S
NER-010901900	SCM-2, 2 Channel Strobe Cntrl.	24V-S
NER-010503500	VPS-II, 2 Ch. Variable PS, US Cord	12V-C
NER-010503501	VPS-II, 2 Ch. Variable PS, EU Cord	12V-C
NER-030003702	Ext. Cable, Cont., 1.8 M (6 ft.)	12V-C & 24V-C
NER-030003703	Ext. Cable, Cont., 3.0 M (10 ft.)	12V-C & 24V-C
NER-030003601	Y cable, 2 Lights, 9 pin D-sub Cont.	12V-C & 24V-C
NER-030007006	Ext. Cable, Strobe, 1.8 M (6 ft.)	24V-S
NER-030007010	Ext. Cable, Strobe, 3.0 M (10 ft.)	24V-S
NER-030006900	Y cable, 2 Lights, 9 pin D-sub Strb.	24V-S

¹ NER-01050140x used only with NER-010901900;

NER-01050260x used with either NER-010502702 or 24V-C lights with DB-9 connectors

Cables/Connectors:

	Connector	Length	Pin#	1	2	3	4	5	6	7	8	9
12V-C Models	9 pin D-sub Male	2.0 M (6.6 ft.)		n/a	n/a	GND	+12VDC	n/a	n/a	n/a	n/a	n/a
24V-S Models	9 pin D-sub Male	2.0 M (6.6 ft.)		V-	n/a	n/a	+24VDC	n/a	n/a	n/a	n/a	n/a
24V-C Models	9 pin D-sub Male	2.0 M (6.6 ft.)		n/a	n/a	n/a	n/a	n/a	n/a	+24VDC	n/a	GND



When provided, affix peel and stick eye safety warning labels to a system location visible to system operators and supporting personnel.

WARNINGS: For safe use of this product, observe the following warnings:

- Handling:** Surfaces hot during and after operation, avoid contact.
- Service:** No user serviceable parts inside, contact supplier for service.
- Eye Safety:** Products containing LEDs fall under the IEC standard for laser product safety (IEC 60825-1). Please refer to the IEC classifications and categorization of NERLITE products below for safe operation.
- IEC Laser Safety Class Definitions pertinent to NERLITE LED products:**

IEC Class Code	Definition
1	Considered as safe to eye and skin under all reasonably foreseeable conditions of operation.
1M	Considered as safe to eye and skin under all reasonably foreseeable conditions of operation, provided they are not viewed with magnifying optics of any kind.
2	Will not cause permanent eye damage under all reasonably foreseeable conditions of operation, provided that any exposure may be terminated by the blink reflex of the eye. Since this assumes the eye can detect this radiation, the wavelength range is limited to visible light (400nm to 700nm).
- IEC Laser Safety Class Codes of NERLITE LED Machine Vision Illuminators**

IEC Class Code	NERLITE Products (Refer to Model Descriptions)
1	R LED, W LED, G LED, I LED
1M	U LED
2	B LED, B1 LED, B3 LED, R1 LED, R3 LED, W1 LED, W3 LED, G1 LED, G3 LED, I1 LED, DUAL AXIS LIGHTS containing I LED
- Training:** Customers are encouraged to document their unique application and instruct employees on procedures to limit exposure to LED radiation. The documentation and instruction should include but not necessarily be limited to:
 - Operational overview of equipment including LED lighting.
 - Need for personal protection (e.g. protective eyewear, UV protective eyewear)
 - Understanding hazard controls (e.g. warning signs)
 - Bio-effects of LED radiation upon the eyes and skin (refer to <http://www.icnirp.de/documents/led.pdf> for the International Commission on Non-ionizing Radiation Protection's statement on "LEDS and Laser Diodes: Implications for Hazard Assessment")
- General LED Precautions:**

These devices contain visible and non-visible LEDs – Light Emitting Diodes.
- WARNING – RISK OF DISCOMFORT:**

Observation of the Class 1 and 2 code definitions are substantial for eye protection.

- Flashing LED Precautions:**

This device contains LEDs – Light Emitting Diodes – that are flashing (aka strobing or pulsing) during operation.
- WARNING – RISK OF DISCOMFORT:**

Flashing (aka strobing or pulsing) lights have been known to cause discomfort in people; you can prevent this by taking precautions during use.

- Ultra Violet (UV) LED Precautions:**

This device contains UV Light LEDs – Ultra Violet Light Emitting Diodes. The LED during operation radiates intense UV light.
- WARNING – RISK OF CORNEA AND LENS DAMAGE:**

Viewing the LED output with certain optical instruments (for example: eye loupes, magnifiers and microscopes) within a distance of 100 mm may pose an eye hazard. During operation, these LEDs radiate UV light, requiring that precautions must be taken to prevent looking directly at the UV light with unprotected eyes. Do not look directly, or through an optical system, into the UV light. When there is a possibility to receive a reflection of light, protect your eyes by using UV light protective glasses so that light will not reach eyes directly.

- Blue LED Precautions:**

This device contains Blue LEDs – Blue Light Emitting Diodes.
- WARNING – RISK OF RETINAL DAMAGE:**

During operation, these LEDs radiate Blue light, requiring that precautions must be taken to prevent looking directly at the Blue light with unprotected eyes. Eye protection from visible "blue light" LED radiation can be provided by normal aversion responses (e.g. looking away from light source, blink reflex).

- Infra Red (IR) LED Precautions:**

This device contains IR LEDs – IR Light Emitting Diodes.
- WARNING – THERMAL HAZARD: RISK OF LENS DAMAGE:**

During operation, these LEDs radiate non-visible thermal energy. Eye hazards are dependent upon brightness of the source and since IR LED output is non-visible, precautions must be taken to prevent looking toward the output of the LED assembly.