

## NERLITE® R-100 "V2" Evaluation Accessories Kit

The **R-100 "V2" Evaluation Accessories Kit** provides a diffused lens, three fresnel (focusing) lenses (70mm, 102mm and 127mm focal lengths) and a lock ring tool to support quick and easy lens changes for product demonstration/evaluation purposes.

Model #	Description
NER-010907002	KIT, R-100 V2 EVAL ACCESSORIES

### Mechanical:

#### Lenses:

**OD x ID x H (mm/in.):** 68.3 mm x 49.3 mm x 1.5 mm  
(2.69 in. x 1.94 in. x 0.06 in.)

**Mounting:** R-70 "V2" Lock Ring

**Material:** Plastic

#### Tool:

**L x W x H (mm/in.):** 101.5 mm x 25.2 mm x 21.0 mm  
(4.00 in. x 0.99 in. x 0.83 in.)

**Material:** Aluminum

**Weight (kit – tool & lenses):** 82.2 grams (2.9 oz.)

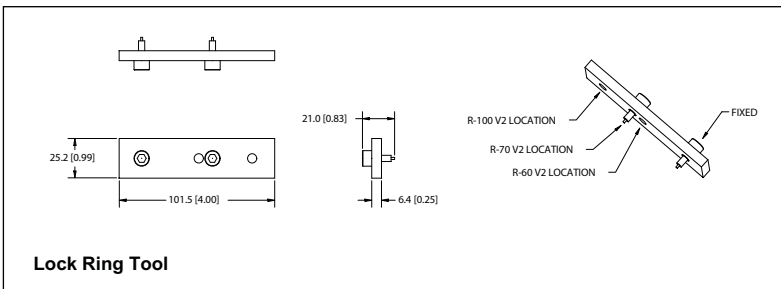
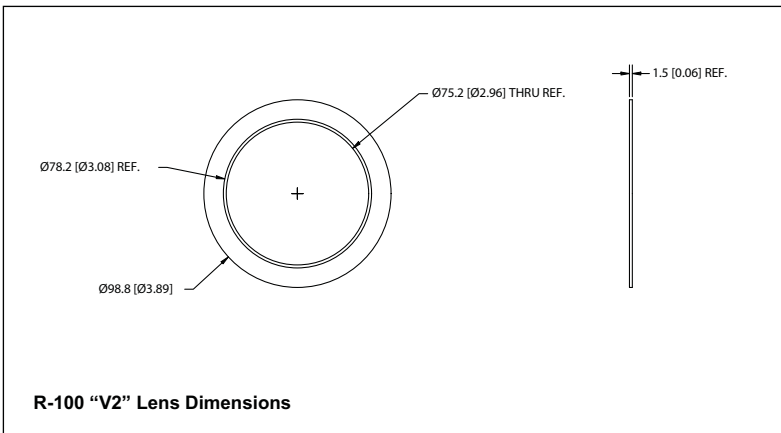

### NERLITE "V2" Ring Lens Interchange Procedure

1. Position "V2" Ring Illuminator (R-60, R-70 or R-100) with lens up on a clean work surface.
2. Place the adjustable pin of the Lock Ring Tool into the appropriate bar hole based on size of Ring Light.
3. Insert pins of Lock Ring Tool into pin holes of the light's lock ring, loosen and remove lock ring (counter-clockwise motion).
4. Lift lens out of housing by inside edges to avoid contamination.
5. Place new lens in housing (handle by edges).
6. Thread lock ring in (clockwise) by hand and tighten with tool.

### Pin Placement:

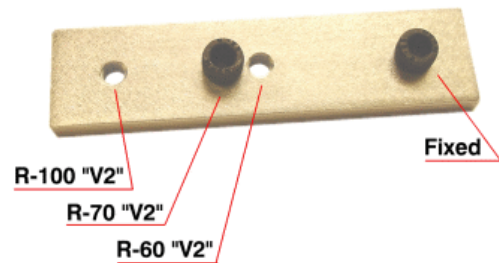

**Lock Ring Tool Pin Placement for "V2" Ring Products**